

# 10-9401 MOUNTING KIT AND HYDRAULIC TANK INSTRUCTIONS

## WARRANTY

Warranty adjustments will be considered on an individual basis on the following criteria:

- Warranty voided upon mounting Non Pro-Tech products to Cabguards, Droms, or Tool Boxes.
- Warranty voided without Pro-Tech Mounting Kit.

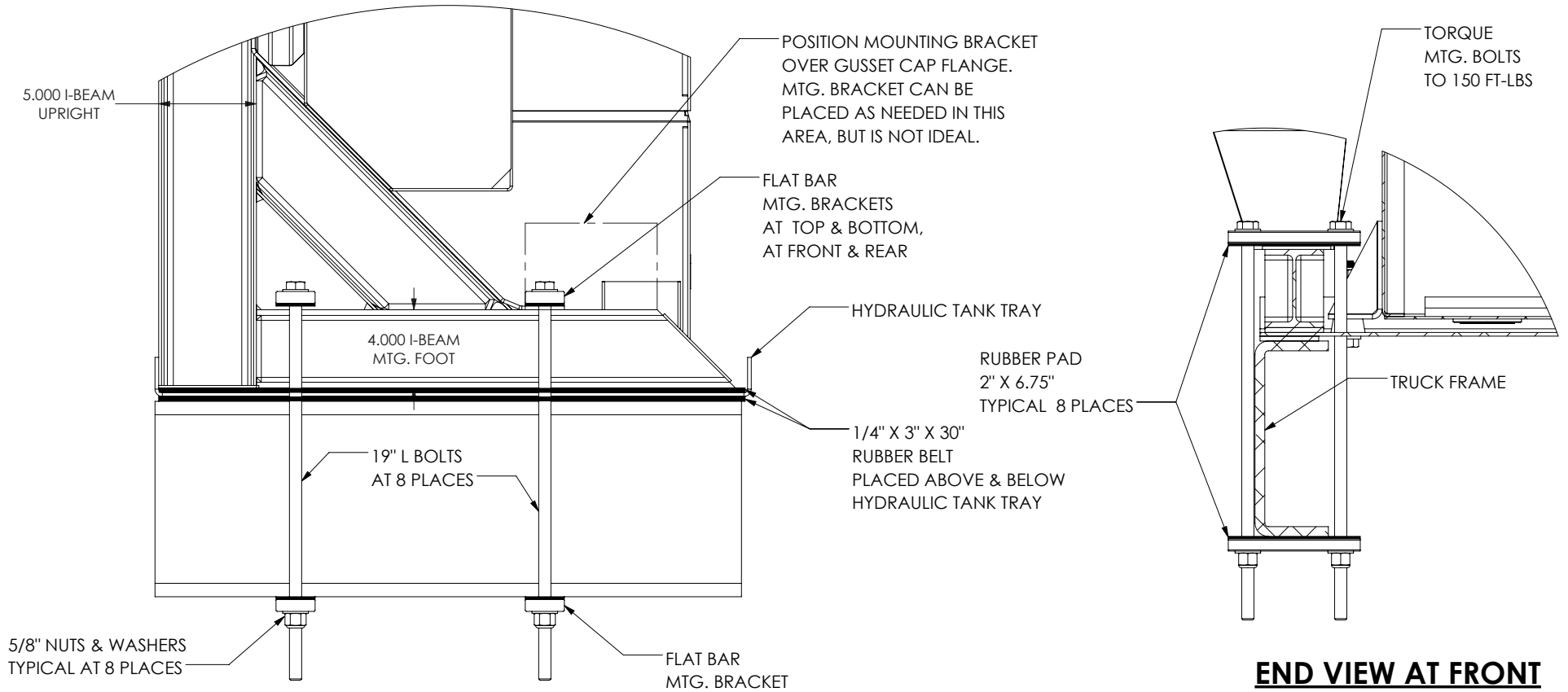

**SIDE VIEW**

**END VIEW AT FRONT MOUNT LOCATION**

**NOTE: HOLES WILL NEED TO BE DRILLED INTO THE HYDRAULIC TANK TRAY FOR THE 19" BOLTS ONCE MOUNTING PLACEMENT HAS BEEN DETERMINED DURING INSTALLATION**

MATERIAL		<b>SEE COMPONENT DRAWINGS</b>			
TOLERANCES ±	UNLESS OTHERWISE SPECIFIED	DRAWN	DATE		
DIMENSIONS SHOWN IN INCHES		AED	3/11/2020	PART NUMBER	
X/XX = ± 1/8		THE INFORMATION CONTAINED IN THIS DRAWING IS THE SOLE PROPERTY OF PROTECH INDUSTRIES ANY REPRODUCTION IN PART OR WHOLE WITHOUT THE WRITTEN PERMISSION OF PROTECH INDUSTRIES IS PROHIBITED.		<b>10-9401 HYDRAULIC TANK INSTRUCTIONS</b>	
X.XXX = ± 0.125		REMOVE ALL BURRS BREAK ALL SHARP EDGES		PROJ	
ANGULAR = ±1.5°		VANCOUVER, WA 98666 PO BOX 933			
DO NOT SCALE DRAWING		LAVERGNE, TN 37086 PO BOX 700		SHEET 1 of 2	
				REV	
				<b>0</b>	

0	INITIAL DRAWING	3/11/2020	763	AED
REV.	DESCRIPTION	DATE	ECN	APPROVED

# 10-9401 MOUNTING KIT INCLUDES THE FOLLOWING:

ITEM NO.	PART NUMBER	DESCRIPTION	QTY.
1	11-9400-02	PAD,STEEL MTG.5/8X2X6.75 GALVANIZED	8
2	11-9400-04	PAD, RUBBER C.GRD MTG.,1/4X3X30 LG	2*
3	90-370200	RUBBER,CR.MTG.1/82X6.75 MASTICATED	8
4	90-410325	WASHER 5/8" FLAT GALV F-436	16
5	90-429520	BT 5/8-11X19LNG & 5IN THRD GR5 ZNC	8
6	90-430258	HEX NYLOCK NUT 5/8-11UNC,ZP	8

\* 2 ADDITIONAL 11-9400-04 (RUBBER PADS) ARE INCLUDED WITH THE ASSOCIATED HYDRAULIC TANK

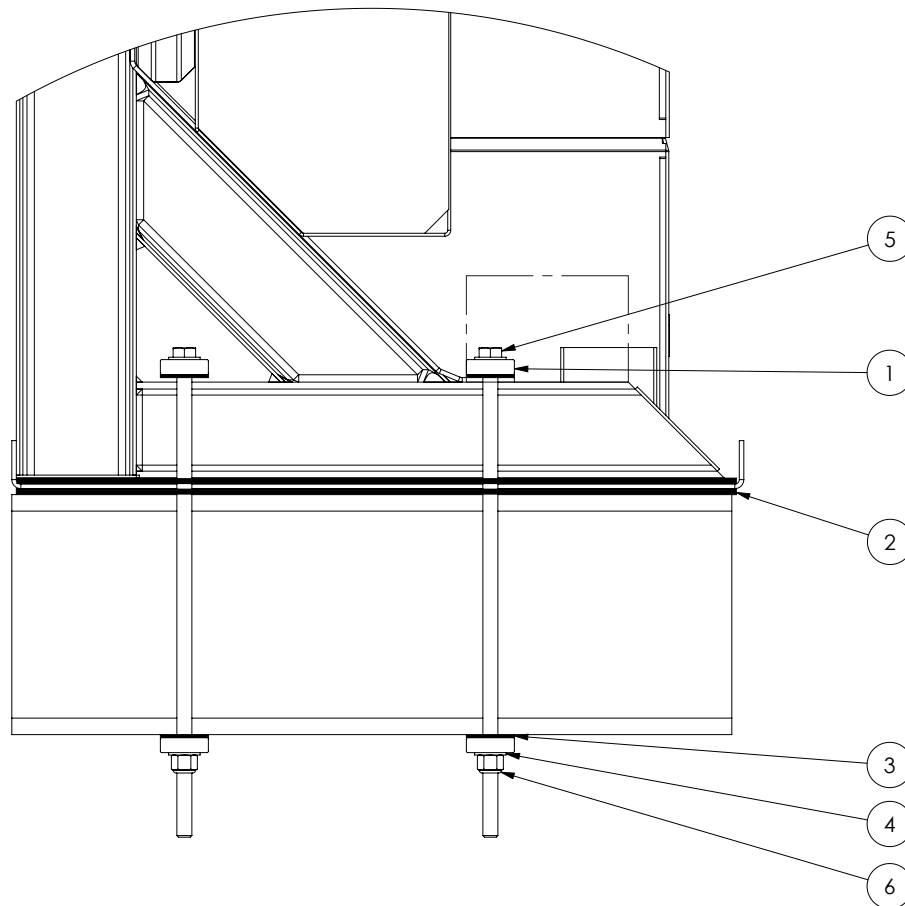

MATERIAL		<b>SEE COMPONENT DRAWINGS</b>	
TOLERANCES ±	DRAWN	DATE	
UNLESS OTHERWISE SPECIFIED	AED	3/11/2020	
DIMENSIONS SHOWN IN INCHES	THE INFORMATION CONTAINED IN THIS DRAWING IS THE SOLE PROPERTY OF PROTECH INDUSTRIES ANY REPRODUCTION IN PART OR WHOLE WITHOUT THE WRITTEN PERMISSION OF PROTECH INDUSTRIES IS PROHIBITED.		
X/XX = ± 1/8	REMOVE ALL BURRS		
X.XXX = ± 0.125	BREAK ALL SHARP EDGES		
ANGULAR = ±1.5°	VANCOUVER, WA 98666		
	PO BOX 933		
	LAVERGNE, TN 37086		
	PO BOX 700		
<b>DO NOT SCALE DRAWING</b>			



DESCRIPTION  
**KIT, CBRCK MTG. (19 IN BTS) & HYDRAULIC TANK APPLICATION**

PART NUMBER  
**10-9401 HYDRAULIC TANK INSTRUCTIONS**

PROJ  SHEET 2 of 2 REV **0**

0	INITIAL DRAWING	3/11/2020	763	AED
REV.	DESCRIPTION	DATE	ECN	APPROVED