

10-9407 MOUNTING KIT AND HYDRAULIC TANK INSTRUCTIONS

WARRANTY

Warranty adjustments will be considered on an individual basis on the following criteria:

- Warranty voided upon mounting Non Pro-Tech products to Cabguards, Droms, or Tool Boxes.
- Warranty voided without Pro-Tech Mounting Kit.

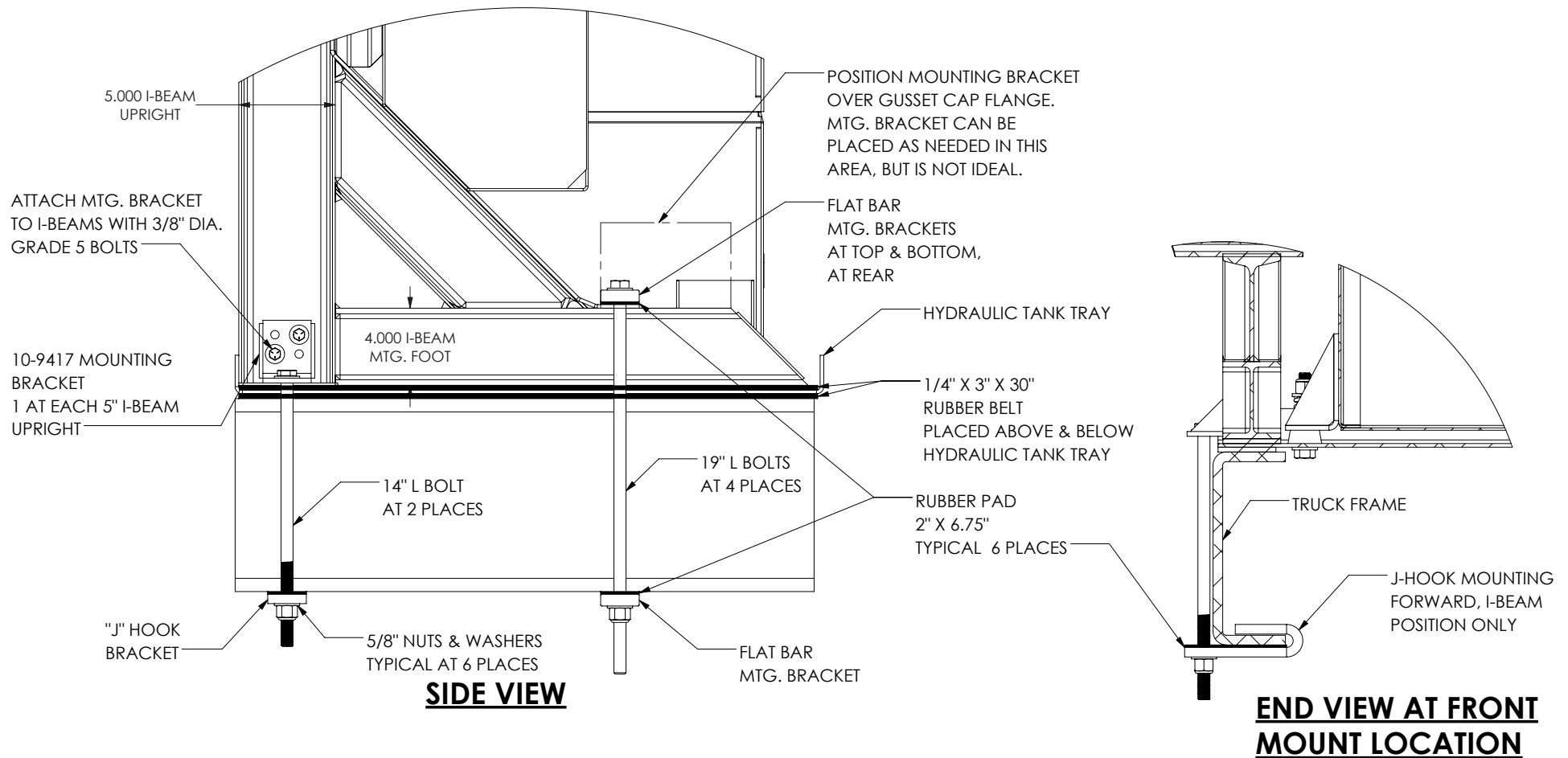

NOTE: HOLES WILL NEED TO BE DRILLED INTO THE HYDRAULIC TANK TRAY FOR THE 19" BOLTS ONCE MOUNTING PLACEMENT HAS BEEN DETERMINED DURING INSTALLATION

MATERIAL		SEE COMPONENT DRAWINGS			
TOLERANCES ±	DRAWN	DATE			
UNLESS OTHERWISE SPECIFIED	AED	3/11/2020		DESCRIPTION	
DIMENSIONS SHOWN IN INCHES	THE INFORMATION CONTAINED IN THIS DRAWING IS THE SOLE PROPERTY OF PROTECH INDUSTRIES ANY REPRODUCTION IN PART OR WHOLE WITHOUT THE WRITTEN PERMISSION OF PROTECH INDUSTRIES IS PROHIBITED.			MTG.KIT,FLAT & J-HOOK FOR STL.FRME & HYDRAULIC TANK APPLICATION	
X/XX = ± 1/8	VANCOUVER, WA 98666			PART NUMBER	
X.XXX = ± 0.125	PO BOX 933			10-9407 HYDRAULIC TANK INSTRUCTIONS	
ANGULAR = ±1.5°	LAVERGNE, TN 37086			PROJ	
REMOVE ALL BURRS	PO BOX 700				
BREAK ALL SHARP EDGES	DO NOT SCALE DRAWING			SHEET 1 of 2	

0	INITIAL DRAWING	3/11/2020	763	AED
REV.	DESCRIPTION	DATE	ECN	APPROVED

10-9407 MOUNTING KIT INCLUDES THE FOLLOWING:

ITEM NO.	PART NUMBER	DESCRIPTION	QTY.
1	10-9417	GALV BRKT ANGLE MTG, ONE HOLE-2.375 OUT	2
2	11-9400-02	PAD, STEEL MTG. 5/8X2X6.75 GALVANIZED	2
3	11-9400-04	PAD, RUBBER C. GRD MTG., 1/4X3X30 LG	4
4	11-9300	J-HOOK FORCED AND GALVNZD STL FRM	2
5	90-370200	RUBBER, CR. MTG. 1/82X6.75 MASTICATED	6
6	90-410038	WASHER 3/8 USS FLAT ZNCPLT (67#)	4
7	90-410325	WASHER 5/8" FLAT GALV F-436	12
8	90-423125	BOLT 3/8 X 1-1/4 GR5 ZNCPLTED-16 THREAD	4
9	90-429515	BT 5/8-11 X 14 LNG & 4 THRD GR5 ZNC	2
10	90-429520	BT 5/8-11 X 19 LNG & 5IN THRD GR5 ZNC	4
11	90-430138	NUT 3/8 NC NYLOC ZINC PLATED	4
12	90-430258	HEX NYLOCK NUT 5/8-11 UNC, ZP	6

* 2 ADDITIONAL 11-9400-04 (RUBBER PADS) ARE INCLUDED WITH THE ASSOCIATED HYDRAULIC TANK

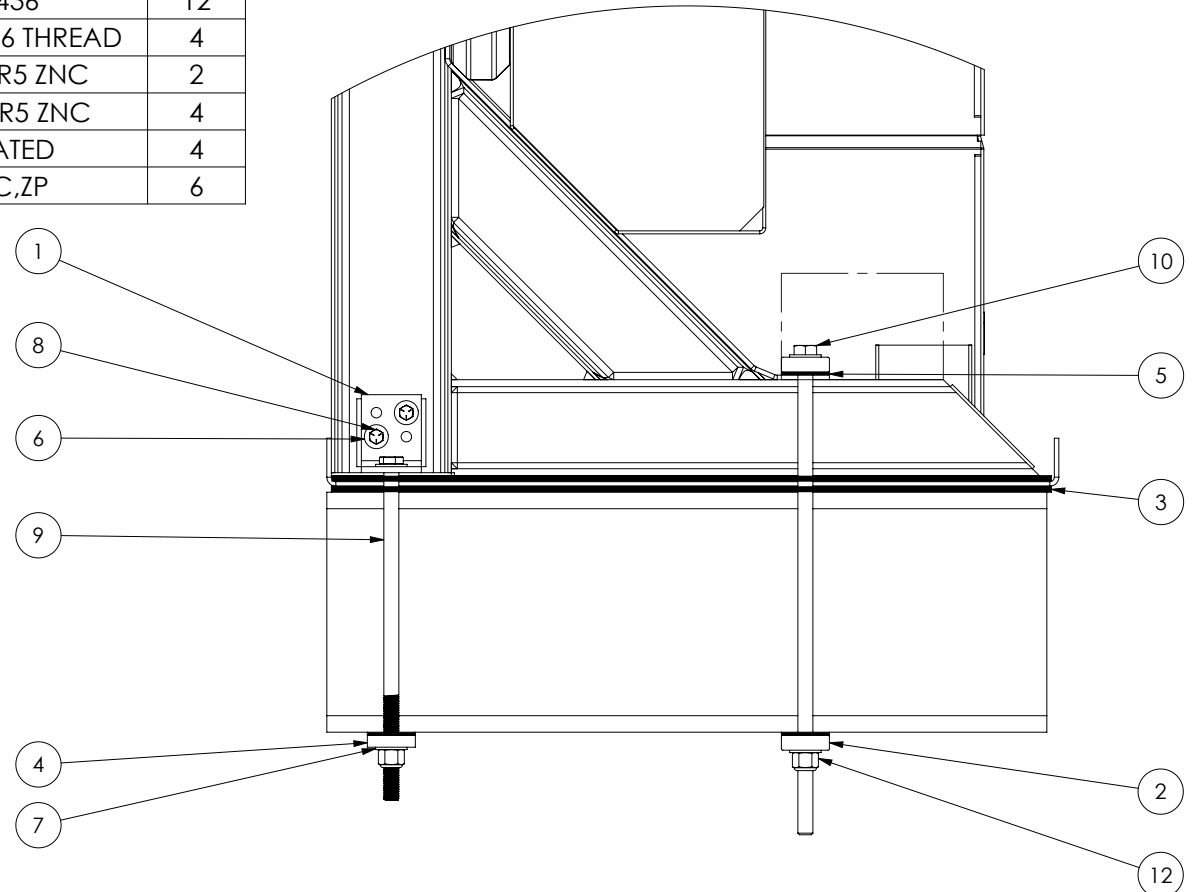

MATERIAL SEE COMPONENT DRAWINGS		DRAWN AED		DATE 3/11/2020	
TOLERANCES ± UNLESS OTHERWISE SPECIFIED		THE INFORMATION CONTAINED IN THIS DRAWING IS THE SOLE PROPERTY OF PROTECH INDUSTRIES ANY REPRODUCTION IN PART OR WHOLE WITHOUT THE WRITTEN PERMISSION OF PROTECH INDUSTRIES IS PROHIBITED.			
DIMENSIONS SHOWN IN INCHES X/XX = ± 1/8 X.XXX = ± 0.125 ANGULAR = ± 1.5°		VANCOUVER, WA 98666 PO BOX 933 LAVERGNE, TN 37086 PO BOX 700			
REMOVE ALL BURRS BREAK ALL SHARP EDGES		DESCRIPTION MTG. KIT, FLAT & J-HOOK FOR STL. FRME & HYDRAULIC TANK APPLICATION			
DO NOT SCALE DRAWING		PART NUMBER 10-9407 HYDRAULIC TANK INSTRUCTIONS			
		PROJ		REV	
		SHEET 2 of 2		0	

0	INITIAL DRAWING	3/11/2020	763	AED
REV.	DESCRIPTION	DATE	ECN	APPROVED